

MASTER 万事达

Specialized in Logistics Equipment

货架系统分册

www.racking.com.cn

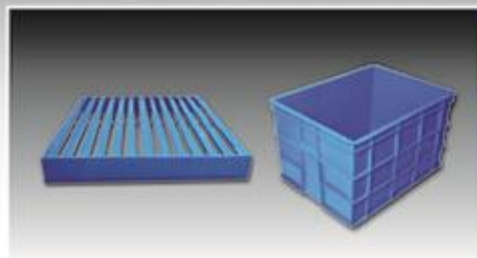

LOGISTIC EQUIPMENT
物流器具



RACKING SYSTEM
货架系统

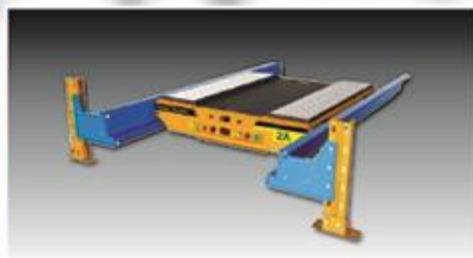

HD-SHUTTLE STORAGE SYSTEM
HD-穿梭车存储系统

ABOUT US

关于我们



天津万事达物流装备有限公司(暨天津市万事达仓储设施有限公司)成立于2001年,经过十余年的发展,在业界的瞩目中公司已成长为国内著名的物流装备提供商及货架制造商,企业综合实力位居行业前列。公司的产品业已通过了ISO9001国际质量标准体系认证、欧洲CE认证、美国RMI认证及澳洲AS认证。公司于2011年被评为天津市“科技型企业”,天津市“科技小巨人”企业,2013年被评为“国家高新技术企业”。

公司制造基地位于天津市武清开发区曹子里拓展区,2013年南厂区一期工程建成后,厂区占地面积已达55000平方米,厂房建筑面积34000平方米。以两条150米全长,最长处理工件长度16米的积放式匹配德国金马喷枪的全自动涂装生产线、全自动焊接机器人及庞大轧机群为代表的众多先进设备使公司年产能高达50000余吨。

坚持科技创新历来作为公司发展的重要方向,在优化传统货架设计的基础上,公司竭力推动以智能子母车密集存储系统、高密度穿梭车存储系统为代表的新型仓储模式的研发和推广。目前公司自主研发的具有完全自主知识产权、综合技术水平达到国内领先水平的高性能穿梭车、智能子母车密集存储系统已成功推向市场,并获得了市场的高度认可。销量位居行业前列。公司将持续致力于密集存储系统的优化和创新,在高密度和自动化存储的研发方面做出不懈努力。未来万事达公司将以更大的热忱专注于物流装备方面的技术革新,全面提升公司产品的技术品质。

做为国内知名、北方地区最大的货架制造企业,公司竭力提升技术和管理水平,在力学计算、结构设计、设备升级等方面不断努力,全面掌握了立库专用超高位货架的设计、制造技术,积极和国内知名的立库集成商合作,向集成商和终端用户提供AS/RS专用高位货架,迄今已完成了数十座立库专用货架的交付。

为应对新的发展挑战,公司组建了营销中心全面负责公司的市场开发及销售管理工作。营销中心下设国内销售部、国际销售部、立库事业部及技术支持部,并在武汉、苏州、重庆、成都、沈阳等地设立了直属销售分支机构。公司拥有进出口自营权,自国际部组建以来,先后参加了数十次广交会、CEMAT、国外专业物流展会,产品成功打入了欧洲、美国、南美、及中东等地区,并受到广泛的赞誉,也成为国外知名物流设备销售商的指定供应商。

■ 总公司:天津万事达物流装备有限公司

地址:天津市武清经济开发区曹子里拓展区

电话:022-26988006 022-26988007

传真:022-26988009

国内销售:sales@racking.com.cn

国际销售:master@racking.com.cn

HTTP://www.racking.com.cn

■ 分支机构:武汉、重庆、成都、苏州、沈阳

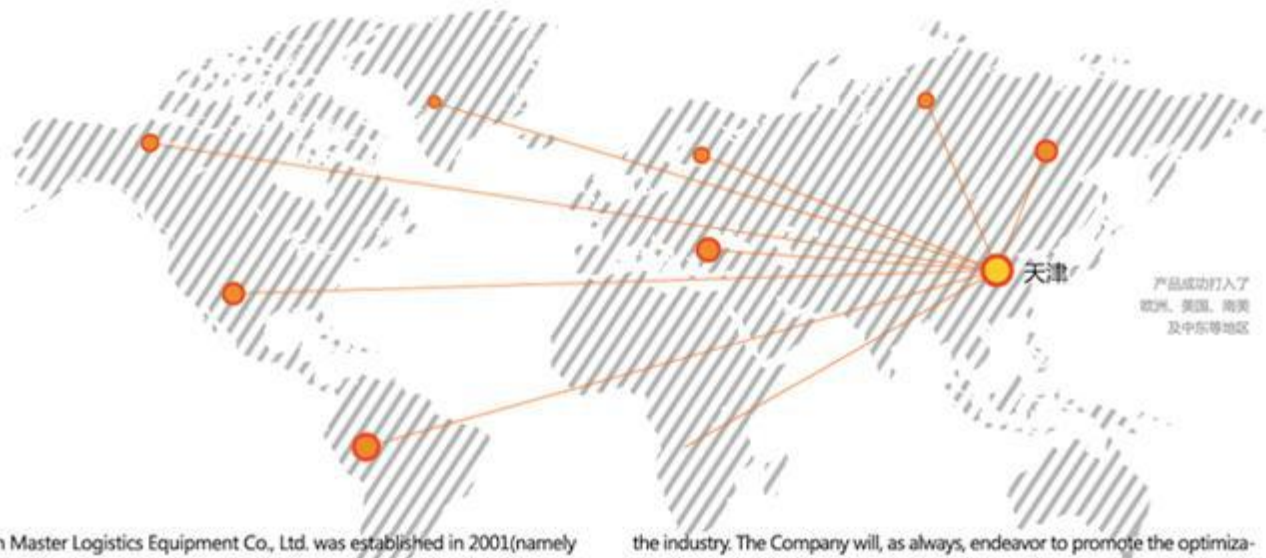

Tianjin Master Logistics Equipment Co., Ltd. was established in 2001 (namely Tianjin Master Storage Facilities Co., Ltd). Through more than ten years of development under attentions of the industry, it has become a well-known provider and manufacturer of logistics equipment in China with top comprehensive strength in the industry. Our Company's products have passed the ISO9001 international quality standard system certification, European CE certification, U.S. RMI certification, and Australian AS certification. In 2011, it has been awarded with the title of Science and Technology Enterprises and Sci-Tech Giant in Tianjin. In 2013, it has been awarded with the title of National High-tech Enterprise.

Our manufacturing base is located at Caozili Expanded Area, Wuqing Development Zone, Tianjin City, it covers a floor area of 55,000 square meters and construction area of 34,000 square meters after Phase I Project of South Zone was completed in 2013. With a number of advanced equipment presented by fully automatic painting production lines of German golden-horse spraying guns and fully automatic painting robots with a length of 150m able to process workpiece at a length up to 16m and rolling mills, the Company has an annual production capacity of up to 50,000 tons.

The Company always adheres to the scientific and technological innovation as an important development direction of the Company. On the basis of optimizing the design of traditional racks, the Company endeavors to promote the development and promotion of new storage model represented by Intelligent Shuttle & Carrier High-density Storage System and High-density Shuttle Storage System. At present, the Company has successfully developed a high-performance shuttle and shuttle & carrier storage system with completely independent intellectual property rights and successfully launched to the market and was highly regarded by markets. The sales is located top in

the industry. The Company will, as always, endeavor to promote the optimization and innovation of high-density and automatic storage system. In the future, Master will continue to focus on the technological innovation of logistics equipment with greater enthusiasm in order to fully improve the technical quality of our products.

As the domestic famous and largest rack manufacturing enterprise in the north area, we endeavor to promote skills and management levels and constantly strive in mechanical calculation, structural design and equipment upgrading, comprehensively master design and manufacturing techniques of stereoscopic warehouse system, positively cooperate with famous domestic stereoscopic warehouse integrators and offer them and end users AS/RS specific high shuttles, it has successfully delivered numerous stereoscopic warehouse system specific racks.

To deal with new development challenges, the Marketing Center was set up by the Company to take all responsibilities for sales and sales management of the Company, under which, there are Domestic Sales Department, International Sales Department, Stereoscopic Business Department and Technical Support Department. It also sets up direct sales branches in Wuhan, Suzhou, Chongqing, Chengdu, Shenyang and other cities. The Company has the right to import and export. Since the establishment of the International Department, it has participated in Canton Fair, CEMAT and foreign professional logistics exhibition for dozens of times, our products have been successfully introduced into Europe, the United States, South America, the Middle East and other regions and have been highly recognized. The Company has also become the designated supplier of well-known international logistics equipment vendors.

PART1
MASTER RACKING



PALLET RACKING

货架 —— 横梁式货架

❖ 横梁式货架

横梁式货架是一种应用最为广泛的货架类型，具有结构稳定，承载能力大，拣选方便等优点。该货架由承载立柱片和横梁组成。横梁与立柱片的连接为挂接式，并设有安全销，可按 50、76mm 节距调整。立柱片和地面采用膨胀螺栓连接。货架底层置地，一般每层放置 2-3 个托盘。横梁长度及立柱片进深由托盘尺寸大小确定。该货架可根据需要灵活适配一些安全或便利性部件，如托盘挡块，托盘后挡，丝网层板，防撞护脚和连接梁等。货架摆布一般分为标准通道式、窄通道式（VNA）、双进深货位式，并适配不同的叉车。因布置的通道较多，故仓库利用率偏低，采用窄通道式（VNA）或双进深式布局设计可以较好地规避此缺点。横梁式货架因其独特的货位管理能力，极其便利的拣选功能使得其成为物流企业等的首选货架类型。

❖ PALLET RACKING

The beam rack is the most widely used rack type, which has advantages of stable structure, high carrying capacity and convenient picking-up. It is composed of load-bearing upright frames and beams, which are connected by hanging with safety pins. The distance can be adjusted at a height of 50 and 76mm. The upright frames are fixed to the ground with expansion bolts. The bottom layer of the rack is placed on the ground with 2-3 pallets in each layer in general. The length of beams and depth of upright frames are depending on the size of pallets. Such a rack can flexibly equip with some safety or convenience components, such as support bar and rear support bar of pallets, wire mesh laminate, anti-collision protector and connecting beams. The rack layout is generally divided into the standard-aisle type, narrow-aisle type (VNA) and double-deep type, equipped with appropriate forklifts. Too many aisles may reduce the utilization rate of the warehouse, but the narrow-aisle type (VNA) and double-deep type can avoid such a shortcoming. In addition, because of its unique cargo management capabilities and extremely convenient pick-up functions, beam racks have become the first choice for logistics companies and other enterprises.





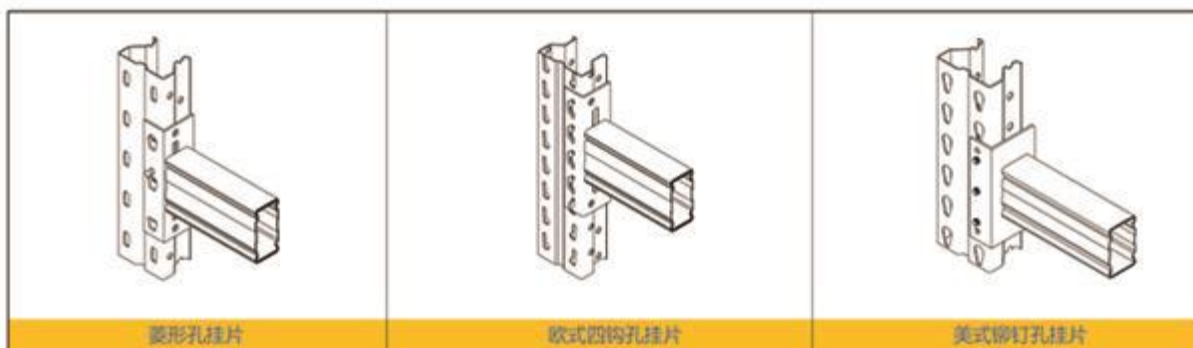
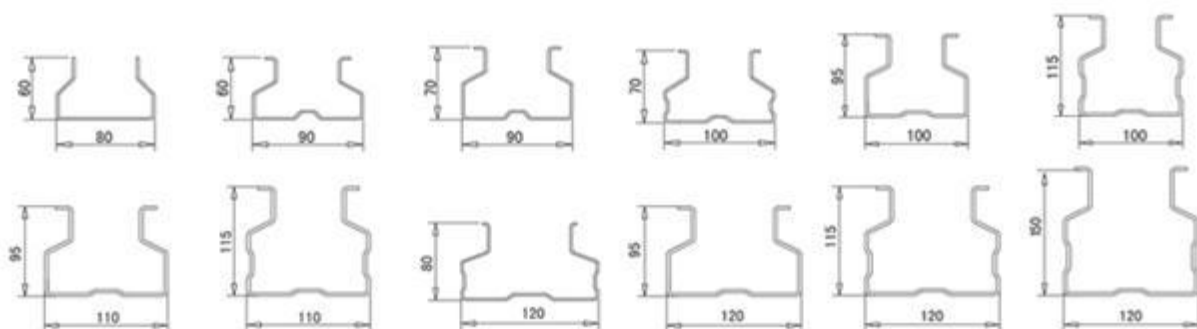

菱形孔挂片

欧式四钩孔挂片

美式铆钉孔挂片

规格	宽度	深度	厚度	单位
● mst-u-8060	80	60	1.5, 2.0	mm
● mst-u-9060	90	60	2.0, 2.3	mm
● mst-u-10070	100	70	2.0, 2.3, 2.5	mm
● mst-u-10095	100	95	2.0, 2.3, 2.5	mm
● mst-u-100115	100	115	2.0, 2.3, 2.5	mm
● mst-u-110115	110	115	2.0, 2.5, 3.0	mm
● mst-u-11095	110	95	2.0, 2.5, 3.0	mm
● mst-u-12080	120	80	2.0, 2.5, 3.0	mm
● mst-u-12095	120	95	2.0, 2.5, 3.0	mm
● mst-u-120115	120	115	2.0, 2.5, 3.0	mm

一体成型横梁

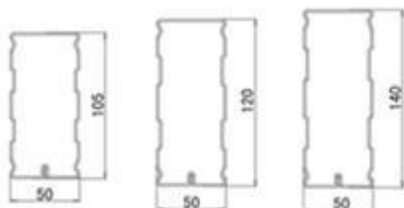

规格	宽度	深度	厚度	单位
● MST-J-105*50	105	50	1.5	mm
● MST-J-120*50	120	50	1.5	mm
● MST-J-140*50	140	50	1.5	mm

抱焊式横梁

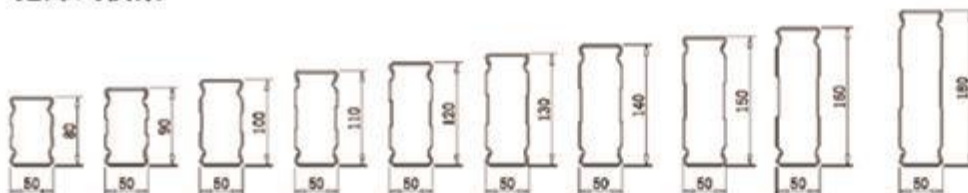

规格	高度	宽度	厚度	单位
● MST-B-80*50	80	50	1.5	mm
● MST-B-90*50	90	50	1.5	mm
● MST-B-100*50	100	50	1.5	mm
● MST-B-110*50	110	50	1.5	mm
● MST-B-120*50	120	50	1.5	mm
● MST-B-130*50	130	50	1.5	mm
● MST-B-140*50	140	50	1.5	mm
● MST-B-150*50	150	50	1.5	mm
● MST-B-160*50	160	50	1.5, 1.8	mm
● MST-B-180*50	180	50	1.5, 1.8	mm

抱焊阶梯型横梁

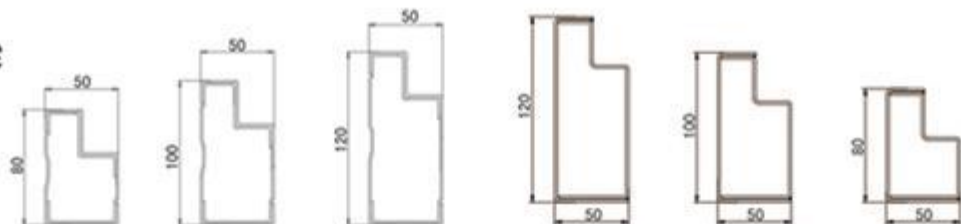

规格	高度	宽度	厚度	单位
● MST-P1-80*50	80	50	1.0—1.8	mm
● MST-P1-100*50	100	50	1.0—1.8	mm
● MST-P1-120*50	120	50	1.0—1.8	mm
● MST-P2-80*50	80	50	1.0—1.8	mm
● MST1-P2-100*50	100	50	1.0—1.8	mm
● MST1-P2-120*50	120	50	1.0—1.8	mm

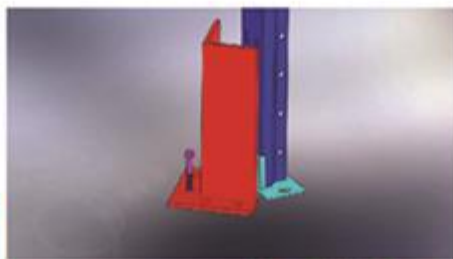

护脚
Upright protector



膨胀螺栓 Expansion bolt



安全销 Locker



叉车通道
Aisle for forklift



防撞护栏
Frame protector



护柱
Upright protector



四爪柱卡
4-hooks beam



丝网层板
Mesh decking



格挡
Pallet support bar

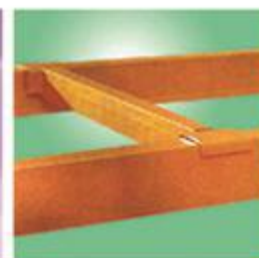

格挡
Pallet support bar



三爪柱卡
3-hooks beam



窄巷道护轨转角
VNA guide rail corner



美式立柱
Teardrop upright

PART 2

MASTER RACKING



DRIVE-IN RACK

货架 —— 驶入式货架

❖ 驶入式货架

驶入式货架又称贯通式货架或通廊式货架，由立柱片组、牛腿、牛腿梁、顶梁、连接顶拉、背拉等组成。该货架类型适用于品种相对较少，整进整出的存储模式，由于只布置主通道，叉车可以驶入存储区，故仓库利用率极高，多被广泛应用在低温冷链物流、饮品、食品、奶制品及其他领域。

平面布局方式分为单向布置和双向布置，一般单向布置以不超过 10 个进深位为宜。在较窄的通道可以设置叉向导向护轨。驶入式货架每层承载不宜超过 1500kg/ 货位。

搬运方式采用前移式叉车或平衡重叉车，亦可采用电动托盘车。

❖ DRIVE-IN RACK

Drive-in rack, also known as drive-through rack, is composed of upright frame groups, corbels, corbel beams, roof beams, top ties and back ties. This type of rack applies to relatively few fields. Because of the full-in and full-out storage mode, only the main aisle shall be arranged, thus the forklift can enter into the storage area. Therefore, the utilization rate of warehouse is very high and this rack is usually widely used in the storage of low-temperature cold chain logistics, drinks, food, dairy and other areas.

Its plan layout pattern is divided into one-way and two-way arrangements. Generally, the one-way layout is appropriate to not exceed 10 depth positions. In the narrow aisle, cross guide rails can also be set up. The carrying load of each story of the drive-in rack shall not be more than 1500kg / cargo space.

In terms of the cargo handling, the forward forklift or counter balanced forklift can be adopted, as well as the electric pallet truck.



轨道梁支撑（牛腿）

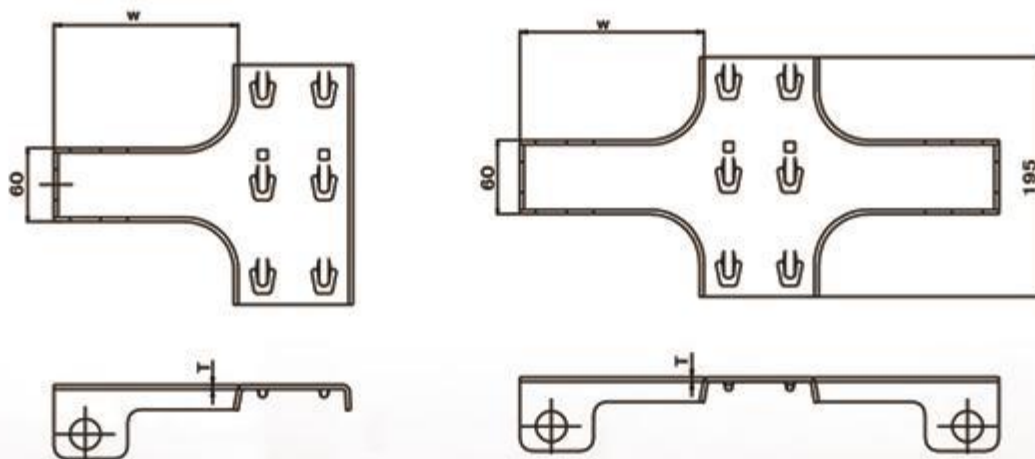

规格	宽度	厚度	单位
● MST-SB135	135	3.5	mm
● MST-SB150	150	3.5	mm
● MST-SB160	160	3.5	mm
● MST-SB180	180	3.5	mm
● MST-DB135	135	3.5	mm
● MST-DB150	150	3.5	mm
● MST-DB160	160	3.5	mm
● MST-DB180	180	3.5	mm

加筋轨道梁 (牛腿梁)

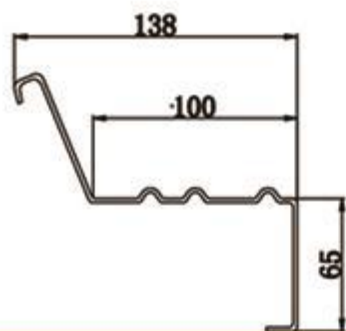

无筋轨道梁 (牛腿梁)

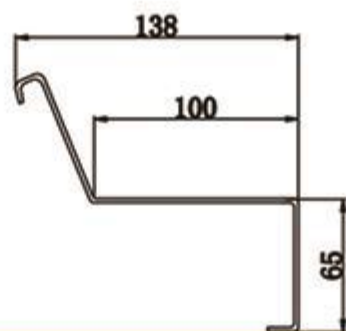

顶拉图

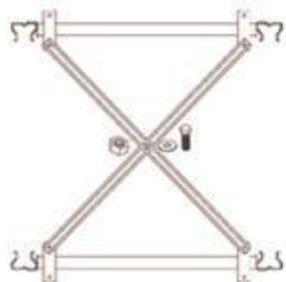

导轨图

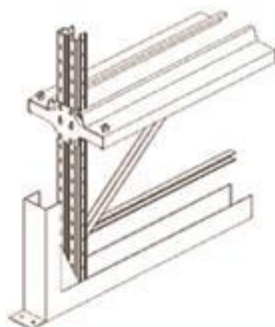

背拉图

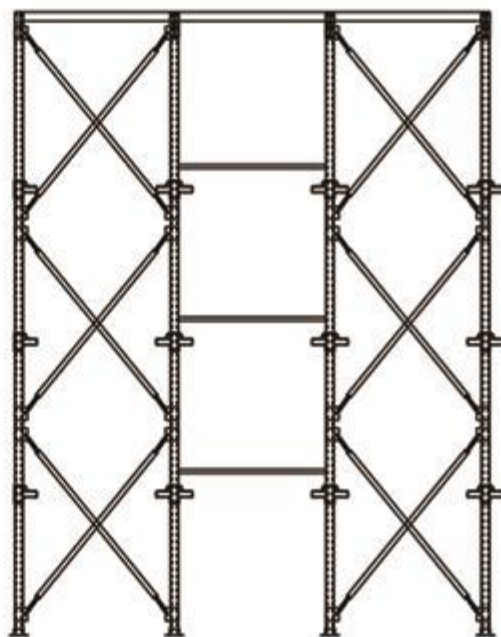

PART 3

LONG SPAN RACKING 1

货架 —— 搁板式货架（无梁型）

❖ 搁板式货架（无梁型）

货架通体为插接式结构，无螺栓连接，无承重横梁。采用挂接式挂片和立柱组成柱片，层板铺在挂片上，挂片上有限位机构防止层板滑落。该货架结构简单，安装方便，通体货架无焊接，外型美观，工艺质量好。层板可按 25 或 50mm 节距调节高度。层板标配多块镀锌板。另可配置空腹腔结构的喷涂层板或折弯加筋层板。另可在货架背部或侧面端部配置背网或背板。在层板上可以布设分隔网或分隔板。

该货架类型主要适用于承重较轻（400kg/层以下）的零备件库快销品库、卖场、仓库等，近年来在电商、速递物流行业的配送仓库使用较为广泛。

❖ Long span Racking 1

The shelf rack is in plug-in structure without bolted connections and load-bearing beams. It adopts hangers and uprights to form upright frames and lays the laminate on the hanger, where there are stop structure to prevent the falling of laminates. Such a rack has simple structure and is easy to install. Due to free of welding, it has good appearance and high quality. The height of laminates can be adjusted at a space of 25 or 50mm.

A few of galvanized sheets are available as standard laminates. In addition, cavity-structure painted laminates or bending reinforced laminates can be available. Back net or plate can also be available for the back or side end of the rack and dividing mesh or plate can be laid on the laminate.

The type of rack is mainly applicable to the warehouse for light-load (400kg / layer below) spare parts, fast-consumable warehouse and shopping malls. In recent years, it has been widely used in the distribution warehouse in the electrical appliance, courier and logistics industry.

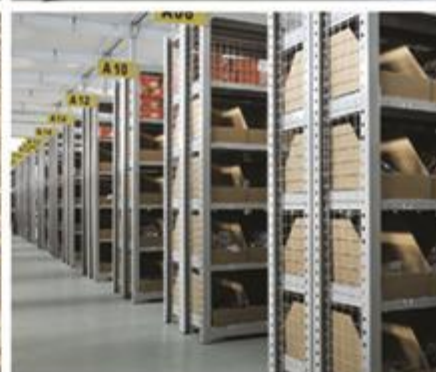

立柱

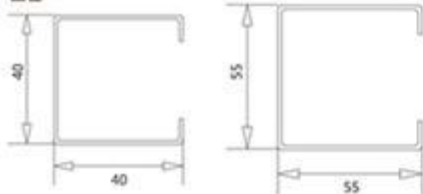

规格	截面	节距	厚度	单位
● MSTU-55	55*55	25,50	1.2-2.0	mm
● MSTU-40	40*40	25,50	1.2-2.0	mm

镀锌层板MSTB系列

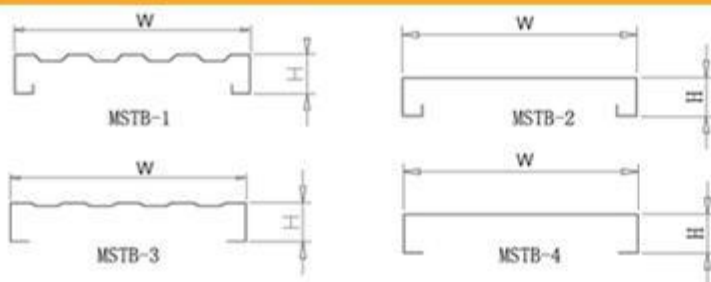

喷涂层板MSTB系列

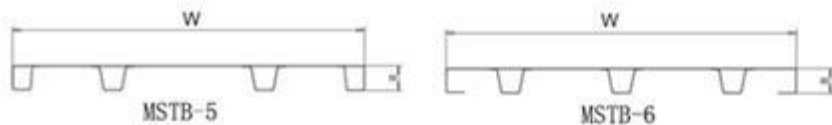

规格	高度	宽度	厚度	单位
● MSTB-1	150-200	25,30 , 35,40	0.5-1.0	mm
● MSTB-2	150-200	25,30 , 35,40	0.5-1.0	mm
● MSTB-3	150-200	25,30 , 35,40	0.5-1.0	mm
● MSTB-4	150-200	25,30 , 35,40	0.5-1.0	mm
● MSTB-5	470/600/800	40	0.5-1.0	mm
● MSTB-6	470/600/800	40	0.5-1.0	mm

PART 4
MASTER RACKING

LONG SPAN RACKING 2

货架—搁板式货架（有梁型）

❖ 搁板式货架（有梁型）

货架由柱片、横梁、层板组成。柱片选用 55*50、80*60 立柱组成。横梁由专用轧机轧制的立面加筋一体 P 型梁、抱焊 P 型梁、P 型管组成。层板标配为多块镀锌板，亦可配点焊喷涂层板、木板、多层板等。

该货架类型具有承载大，结构稳定规格（高度、长度）不受限的特点。可根据需要设计为三立柱柱片组形式，从而解决进深过大及单层承载过大的问题。有梁形货架较适宜存放五金电料、机修组件等较重荷载的产品，该货架也是用于设计多层阁楼式货架的首选货架形式

❖ Long span Racking 2

The rack is composed of upright frames, beams and laminates. The upright frame is composed of 55*50 and 80*60 uprights, while the beam consists of the facade reinforced P-type beam, welded P-type beam and P-type tube, and the standard laminate is galvanized sheet. Also, the spot-welded painted laminates, wooden plates and multi-layer boards etc. can be available.

This type of rack is characterized by large carrying capacity, stable structure and unlimited specifications (height, length). It can be designed as three-upright-unit form as needed to solve the problem in depth and over load of single layer. This type of rack with beams is more appropriate to store hardware and electrical materials, machine repair components and other heavy-load products. It is also the first choice to design rack mezzanine.



PART5

MASTER RACKING



LIGHT-DUTY CANTILEVER RACKING

货架 —— 悬臂式货架 ❖

重型立柱



次重型立柱



200型工字钢

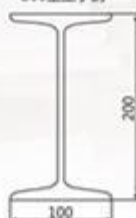

140型工字钢



梯形板



规格 TYPE OF BEAM	H1	H2	厚度	单位
● MST-XB10080	100	80	2.0—2.5	mm
● MST-XB12080	120	80	2.0—2.5	mm
● MST-XB14080	140	80	2.0—2.5	mm
● MST-XB140100	140	100	2.0—2.5	mm
● MST-XB160100	140	100	2.0—2.5	mm
● MST-XB180100	140	100	2.0—2.5	mm



PART 6

MASTER RACKING



MEZZANINE RACKING

货架 —— 阁楼式货架

❖ 阁楼式货架

阁楼式货架是指利用货架作为支撑,在货架的特定高度铺设通道楼板、护栏、人行楼梯、货物滑道、货梯、液压升降平台等,从而设计成二层或多层式储物单元,节约高效利用仓库,提高使用效率的一种货架形式。另外在货架的顶端可以加设整层楼板成为钢质平台,形成下部货架,上部平台的零、整货分区码放的格局,亦可在平台上再灵活设计货架。

此种货架稳定性好,安全性高,设计科学,安装方便。楼板可设计成镂空式满足采光及消防淋水的要求,也可根据需要在通道处设计照明系统解决采光问题。

❖ Mezzanine Racking

The rack mezzanine is a kind of rack which adopts the rack as a support and lays access floors, guard rails, pedestrian stairs, cargo chutes, freight elevators and hydraulic lift platforms to become a two-story or multi-story storage unit. It can save space and efficiently use the warehouse to improve the utilization efficiency. In addition, at the top of the rack, the entire floor slab can be added to set up a steel platform, so as to form a goods placing pattern with lower rack and upper platform. Another rack can also be flexibly designed on the platform.

Such a rack is stable, safe and easy to install due to the scientific design. The floor can be designed into the hollow style to meet the requirements for lighting and fire fighting. Otherwise, the lighting problem can also be solved by designing a lighting system at the access.





标准楼板



镂空楼板



花纹楼板



格栅板

样式 STYLE	高度 (H)	宽度 (W)	厚度 (D)	单位
● 标准楼板	30 40	180 — 220	2.0 — 2.5	mm
● 镂空楼板	29 40	180 — 219	2.0 — 2.5	mm
● 花纹楼板	30 40	180 — 220	2.0 — 2.5 — 3.0	mm
● 格栅板	40	可定做	4.0	mm



PART 7
MASTER RACKING

PLATFORM RACKING

货架 — 钢结构平台

❖ 钢结构平台

钢结构平台是指利用方钢、圆钢、H型钢作为立柱，使用H型钢或专用C型、抱扣梁作为楼面承载层，按钢结构设计规范要求的连接方式连接，用特制钢阁楼板作为楼面层，采用高强螺栓及专用紧固件连接各部件及楼面板的一种货架形式。楼板可以根据客户的需要选用冲孔楼板或钢格栅楼板以满足增强采光或消防喷淋等需要。该货架类型具有承载力大，设计灵活，使用方便，安装便捷的特点，广泛适用于车间或仓库内区域，有效地增加仓库的库容量，适用于可以堆码放置的物品摆放，平台的顶层可以运行托盘搬运车等，设计承重一般为每平方米1000kg以下。可适配液压升降平台、货梯或叉车存取货物。对于较高的仓库可以设计成两层或两层以上的钢结构平台。

另外利用重型货架的立柱组作为支撑，搭建平台式货架，楼面可以选用钢板及木板。此种设计曾广泛适用于白色家电等重量较轻适合于堆码方式存储的仓储方式。

❖ Platform Racking

The steel platform is a form of rack which adopts square steel, round steel and H beam as uprights, H beams or dedicated C-type and buckle beams as the floor bearer, which are connected according to the steel structure design specifications, and applies special steel attic panel as the floor layer and high-strength bolts and special fasteners to connect various components and floor panel. The punched plates or steel grille floor can be selected to meet the requirements for improvement in lighting or fire sprinkling. Such a rack type is characterized by large carrying capacity, flexible design, easy to use and simple installation, and has been widely used in the workshop or warehouse to effectively increase the storage capacity of the warehouse. It is suitable to store goods which can be stacked. The top of the platform can carry pallet trucks, etc., which designed load-bearing is generally below 1000kg per square meter. Also, it can be fitted with hydraulic lifting platform, freight elevator or forklift to access to goods. As for the high warehouse, two or more layers of steel platform can be designed.

In addition, when the upright group of heavy-duty shelves is used for support to build a platform rack, steel and wooden plates can be used for the floor. Such a design has been widely applied to the storage of major appliances and other light goods which are suitable for stacking.





主梁和立柱连接



主梁和次梁连接



立柱柱脚板连接

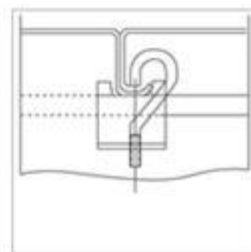

楼板梁和楼板连接

样式 STYLE	高度 (H)	宽度 (W)	厚度 (D)	单位
● 标准楼板	30 40	180—220	2.0—2.5	mm
● 镂空楼板	30 40	180—220	2.0—2.5	mm
● 格栅板	40		4.0	mm



标准楼板



镂空楼板



花纹楼板



格栅板

样式 STYLE	高度 (H)	宽度 (W)	厚度 (D)	单位
● 标准楼板	30 40	180—220	2.0—2.5	mm
● 镂空楼板	29 40	180—219	2.0—2.5	mm
● 花纹楼板	30 40	180—220	2.0—2.5—3.0	mm
● 格栅板	40	可定做	4.0	mm

PART8
MASTER RACKING



CARTON FLOW RACKING + PIPE

货架 —— 流力式货架 + 线棒 ❖

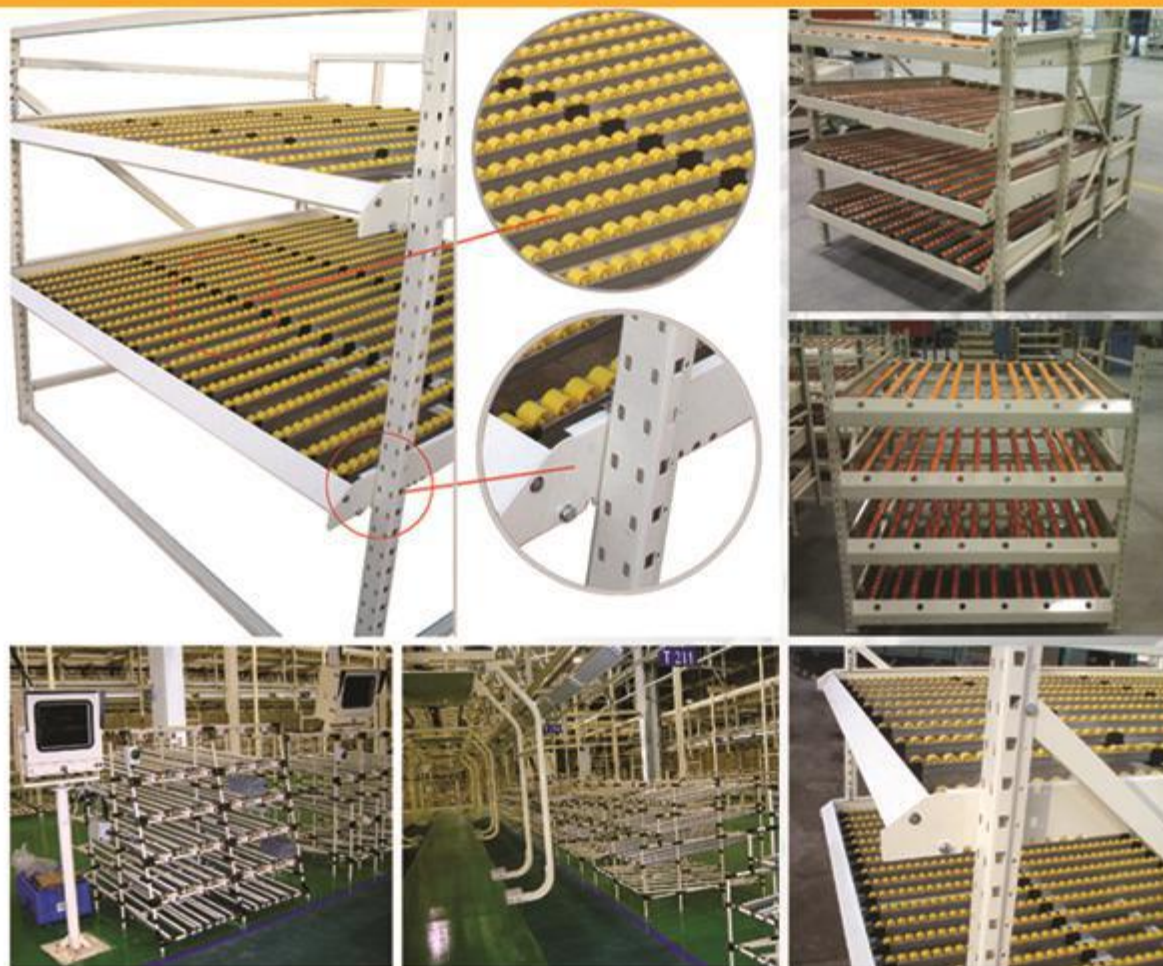

PART9
MASTER RACKING

GRAVITY RACKING

货架 —— 重力式货架 (辊筒式)

❖ 重力式货架

托盘依重力作用在倾斜的输送道上依次移动，达到存储与输送的结合。

货架由立柱片组、承载梁、托辊、阻尼辊、缓冲分离器组成。根据托盘的摩擦系数，托辊的灵活度确定最适当的倾角。将安装完托辊后的输送道固定在巷道内，并根据托盘自重适当的地方布设阻尼托辊，以防止滚动速度过快。输送道的最低端设置缓冲分离器，以便最下端的托盘可以顺利取出。

重力式货架具有“先进先出”，利用率高，存储和输送相结合，安全高效的优点。

❖ Gravity Racking

The pallet moves on the inclined conveyor by order under the effect of gravity to achieve a combination of storage and conveyance.

This type of rack is composed of upright frames, bearing beams, rollers, damping rolls and buffer separators. The most appropriate inclination shall be determined by the friction coefficient of pallets and flexibility of rollers. After fix the conveyor with rollers in the aisle, damping rolls shall be set at the appropriate location according to the pallet weight to prevent rollers from rolling too fast. At the lowest end of the conveyor, a buffer separator shall be applied to facilitate the smooth removal of pallet at the bottom.

Live pallet rack has a few of advantages, such as the FIFO, high utilization, combination of storage and transportation, security and efficiency.



PART 10
MASTER RACKING

PUSH-BACK RACKING

货架 —— 后推式货架

❖ 后推式货架

压入式货架由立柱片、横梁、轨道、托盘车等组成。将专用轨道按设定的角度固定在承载横梁上，托盘车在轨道上运行。托盘采用嵌套式布置，后入的货物依次将先入的货物推至进深方向，取货时先取最外边托盘，最近相邻的托盘因重力作用自动下滑一个货位。实现自动出货。存取方式为先进后出式。

此种货架相较驶入式及双深横梁式货架类型具有存取货方便特点，同时存储密度较大，仓库利用率较高。托盘进深以不超五个为宜。

❖ Push-back Racking

Push-back rack is composed of upright frames, beams, tracks, pallet trucks and so on. Special tracks are fixed on the bearing beam at the set angle and pallet trucks run on it. As all pallets are nested, the goods later in will push the goods first in into the deep direction. At the time of pickup, the outer pallet will be picked up firstly, while the adjacent pallets will automatically let down by gravity to realize automatic delivery. With this type of rack, all goods are stored by the way of first in and last out.

Compared with drive-in rack and double-deep beam rack, this type of rack is more convenient to access to and pick up goods with high storage density and storage utilization. In general, the depth is appropriate to not exceed five pallets.



PART 11
MASTER RACKING**DRAWER RACKING**

货架 —— 模具架

❖ **模具货架**

模具货架又称抽屉式货架，其特点是货物的存放层可以部分抽出或近乎全部抽出，以方便使用天车存取重型模具或工件。另货架顶端也可以根据需要设计电动、手动简易起重设备。该货架承重大，结构复杂，完全模具化生产，较难满足特殊规格定制要求。

❖ **Drawer Racking**

Mold rack is also known as the drawer rack. Its storage layer of goods can be partly or fully pulled out to facilitate to store or pick out the heavy mold or workpiece with crown block. In addition, simple electric or manual lifting equipment can be designed and set up at the top of rack as needed. This rack has a high load-bearing capacity and complex structure and is produced by molds, which is difficult to meet the requirements for customization at special specifications.



PART 12
MASTER RACKING

PALLET SHUTTLE RACKING

货架 —— HD 高密度穿梭车存储系统

❖ HD 高密度穿梭车存储系统

专门设计的货架系统可以和穿梭车进行良好的匹配。该货架系统由立柱片、连接件、专用牛腿式连接梁、专用镀锌轨道及立柱下端的可调节式底脚组成。为更好地方便叉车作业人员作业，在轨道初始端又设计了托盘限位梁，及叉车限位器，在轨道的两端轨道面上又安装了用于机械限位的安全挡片，确保小车的作业安全。

一体冲压焊接的牛腿连接梁将立柱及轨道连接起来，使货架连接成一个单元整体，根据层数不同设计了水平斜拉，不仅保证了货架各方向的精度，也大大提高了其整体稳定性及抗震设防强度。

穿梭车轨道为一次成型轧制的专用轨道，下层为穿梭车行走层，上层为托盘放置层，穿梭车轨道上部采用宽口设计，方便叉车将穿梭车放入轨道。

立柱底部的可调节式底脚设计为高强度螺栓，可以调节高度，不仅可以确保高度方向上的安装精度，还可以有效降低地面的不均匀沉降带来的影响。

❖ Pallet Shuttle Racking

The specially designed rack system can match with the shuttle perfectly. The rack system consists of pillar slice, connecting fitting, dedicated bracket-type connecting beam, dedicated zinc plated rail and the adjustable bottom studs at the bottom end of pillar. In order to facilitate the operation of forklift operators, the pallet limiting beam and forklift limiting stopper are designed at the beginning end of rail and the safety stopper is also installed on the orbit plane of rails for mechanical limiting to ensure the safe operation of shuttles.

The bracket-type connecting beam that is punched and welded wholly connects the pillar slices and rail, making the rack become one unit whole set. Horizontal diagonal pulling is designed according to different layer number, which not only ensures the precision of rack in all directions but also improves its overall stability and seismic fortification intensity.

The rail of shuttle is the dedicated rail that is made by one-step molding. The bottom layer is the travel layer of

shuttle and the top layer is the layer to place the pallets. The top of shuttle rail adopts wide mouth design, which facilitates to place the shuttle onto the rail.

The adjustable bottom studs at the bottom of pillar slice are designed with high strength bolts with height adjusted. It not only ensures the installation precision in the height direction but also reduces the influence brought by differential settlement of ground effectively.

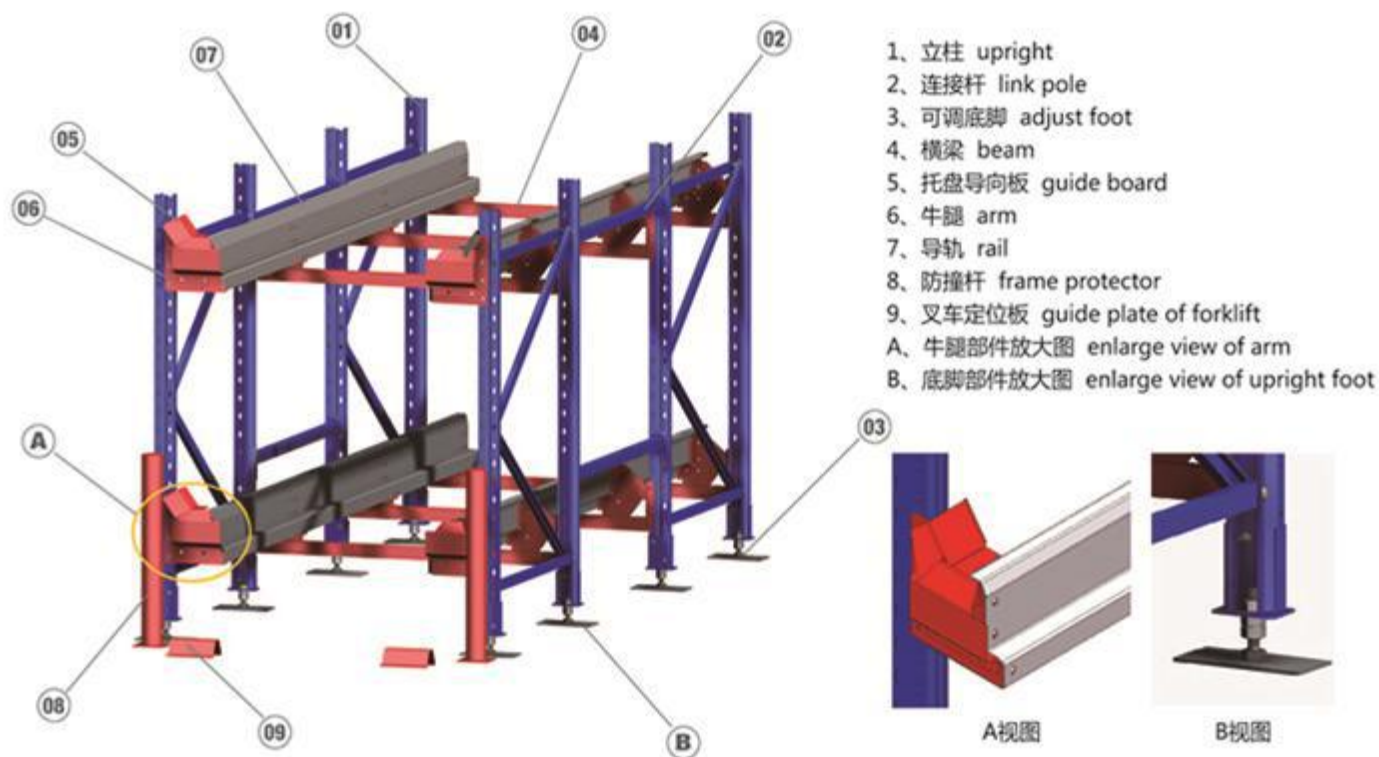



PART13

MASTER RACKING

AS/RS RACKING SYSTEM

货架 —— 自动化立体仓库货架系统 (AS/RS)

❖ 自动化立体仓库货架系统

AS/RS 为目前仓储系统最为高端的存储方式之一，整个系统由货架系统、提升系统、输送系统、控制系统及 WMS 管理系统组成，具有自动化程度高，存储量大，管理科学等特点。近年来在食品、医药、烟草、能源、军工等行业广泛使用。

我司主要是通过向客户或系统集成商提供货架系统来合作建设自动化立体仓库。自动化仓库对货架系统的要求高于一般货架，主要在力学计算，有限元分析，材料供应、生产精度控制、工程安装等诸方面都有较高的要求。

我司力学计算中心可从事静、动力学分析，一般抗震分析，使用 SAP2000 分析软件进行钢结构的有限元分析。生产系统备有两条高精度自动冲床生产线 (NC500*5)，可保证柱孔冲孔精度。两条积放式自动涂装生产线可喷涂最长达 16 米长的工件，保证在 16 米全高内立柱不需要对接。从 8060 到 120150 共有多种不同截面立柱可供选择。自动横梁纵缝焊接专机可以保证横梁焊接的品质。我司备有专门从事立体库货架安装的专业队伍，安装经验丰富。

❖ As/rs Racking System

AS / RS is currently one of the most high-end storage systems. The entire system consists of a rack system, lifting system, conveyor system, control system and WMS management system and is characterized by high degree of automation, large storage capacity and scientific management. In recent years, it has been widely used in food, medicine, tobacco, energy, military and other industries.

Our Company mainly cooperates with customers or system integrators to build automated warehouse by providing the rack system. The automated warehouse has higher requirements for the rack system than general rack system in terms of the mechanical calculations, finite element analysis, material supply, production precision control, engineering installation and storage.

Our Mechanical Calculation Center can engage in the static and dynamic analysis of mechanics, general seismic analysis and finite element analysis of steel structure by use of ANALYSIS software. The production system is equipped with two high-precision automatic impulse production lines (NC500*5), which may control the accuracy error of upright holes. The two accumulation-type automatic painting production lines are able to paint workpiece as long as 16 meters to avoid joint of 16m-high inner upright. There are seven kinds of uprights with different sections ranging from 8060 to 120150 available for choose. With automatic beam longitudinal-seam welding machine, we can guarantee the quality of beam welding. In addition, there are professional team specialized in the installation of warehouse rack with rich experience.





Solidity / Excellence / Foresight

坚实

卓越

前瞻



全国免费
服务热线

400-633-0186